

# Quadband SMD Antenna

Part No. GA249040QP01



## Product Specification



Dimension: 24mmx8mmx4mm

### ➤ Applications

- Smart phone
- Tablets
- Laptops
- Wireless modules
- Tracking devices
- Remote monitoring

### ➤ Features

- Designed for GSM + UMTS/WCDMA(900/1800/1900/2100)
- High efficiency
- Linear Polarization
- Omni- Directional ( *PCB dimension dependent* )
- Minimum PCB clearance
- SMD mounting
- Low Profile, miniature and light weight
- Tape and reel packaging
- RoHS Compliance

### ➤ Customer Services (Optional)

- EM Antenna Simulation for optimum placement of antenna on PCB.
- Lump Elements Matching for optimum antenna performance.
- Anechoic Chamber Measurement for antenna performance validation.

GA STANDARD ANTENNA

# Quadband SMD Antenna

Part No. GA249040QP01

## Specification

ELECTRICAL				
Band	900	1800	1900	2100
S11	< -6dB	< -5dB	< -6dB	< -5dB
VSWR	< 3:1	< 3.5:1	< 3:1	< 3.5:1
Peak Gain (dBi)	0.97	2.27	2.01	2.27
Average Efficiency (%)	50	60	65	65
Impedance (Ohms)	50			
Polarization	Linear			
Radiation Pattern	Omni			
MECHANICAL				
Dimension	24mm x 8mm x 4 mm			
Weight	1.5 g			
ENVIROMENTAL				
Temperature Range	-25°C to +80°C			
Humidity	65°C 95% RH			

## Efficiency with Reference Board

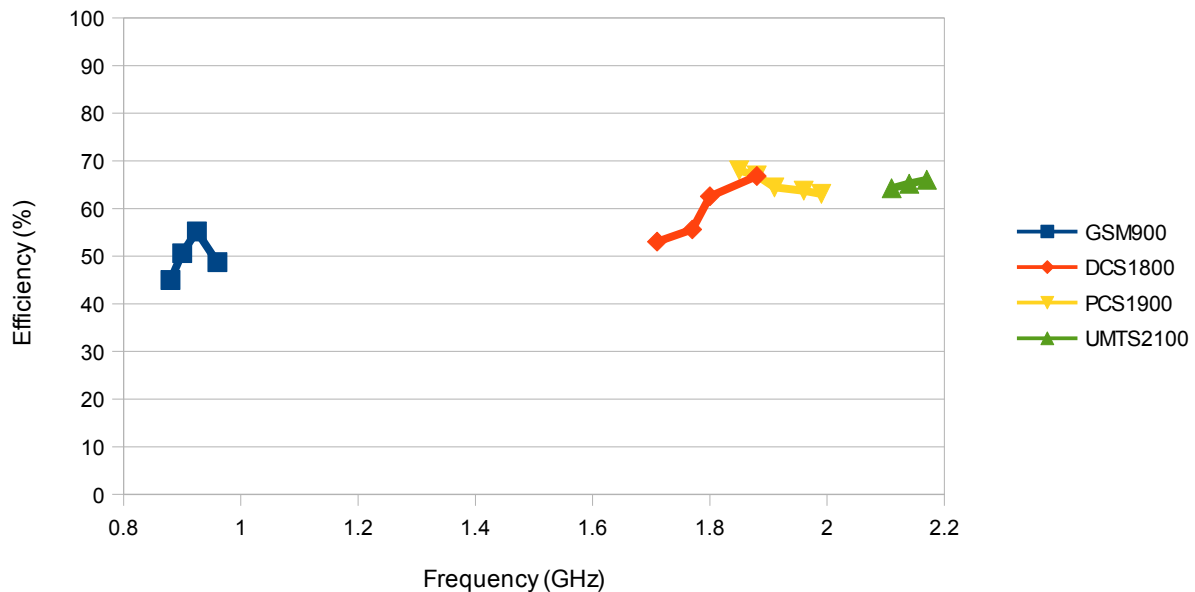

# Quadband SMD Antenna

Part No. GA249040QP01

● Performance with reference board

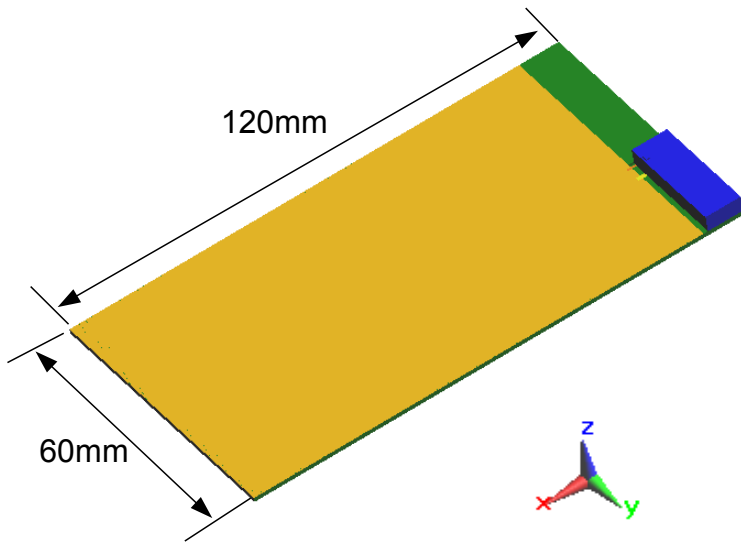
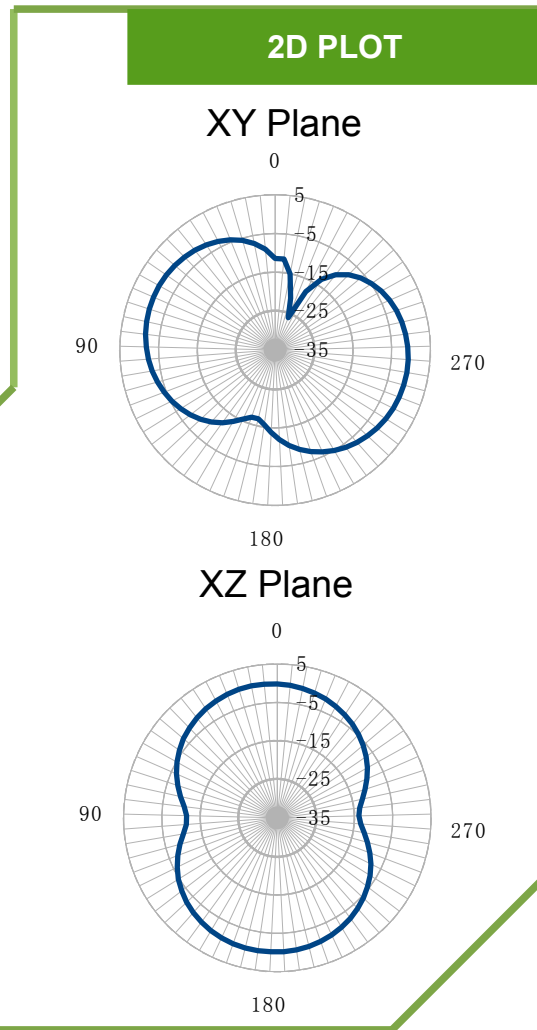
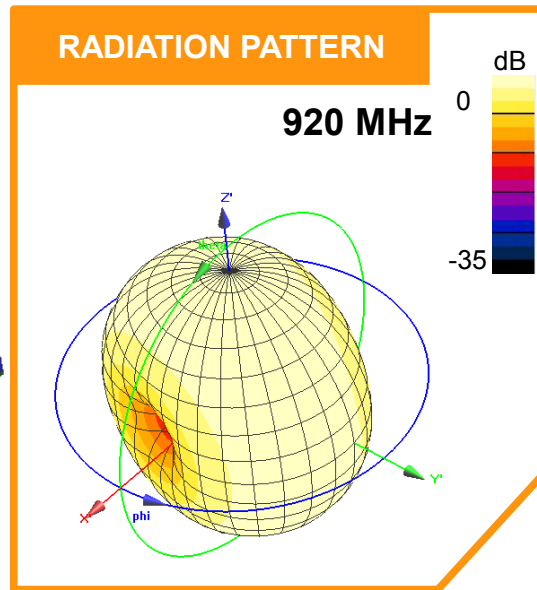

Figure 1, Antenna on reference board

Antenna Placement: Top



# Quadband SMD Antenna

Part No. GA249040QP01

## ● Performance with reference board

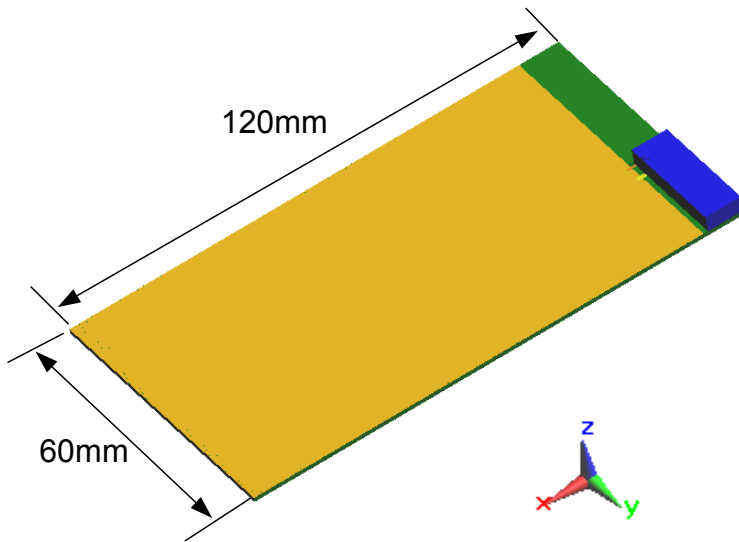
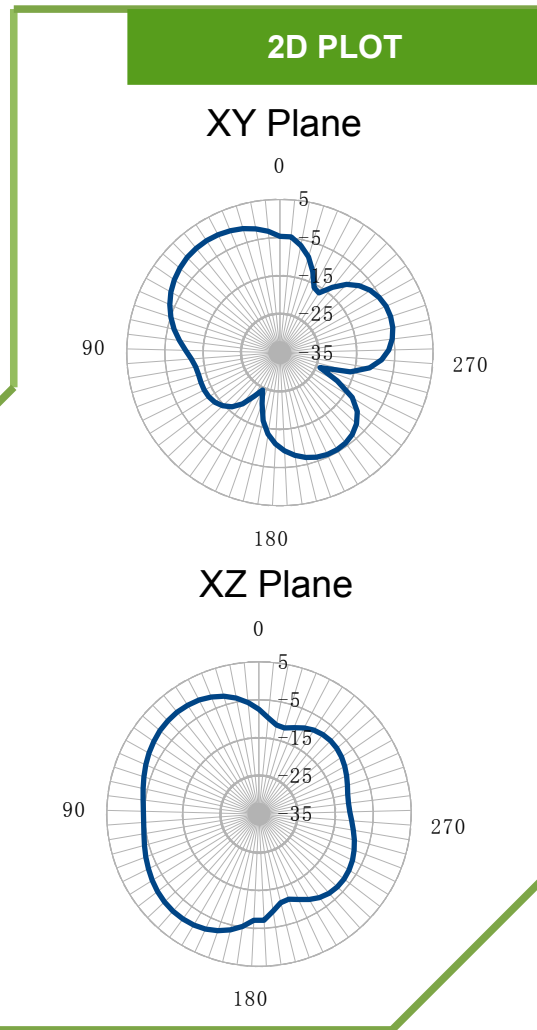
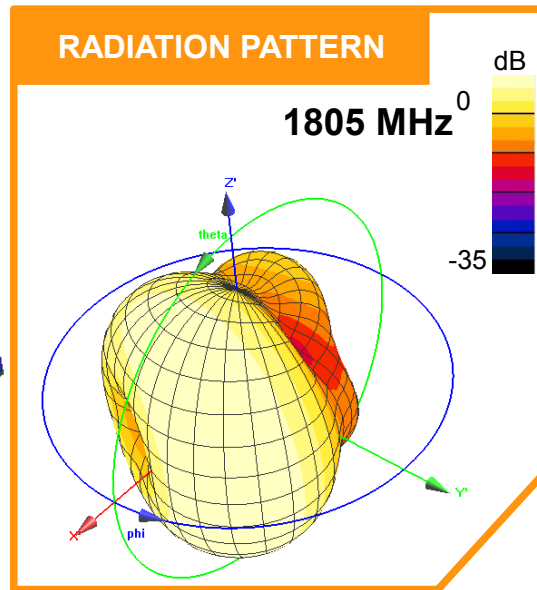

Figure 2, Antenna on reference board

Antenna Placement: Top



# Quadband SMD Antenna

Part No. GA249040QP01

● Performance with reference board

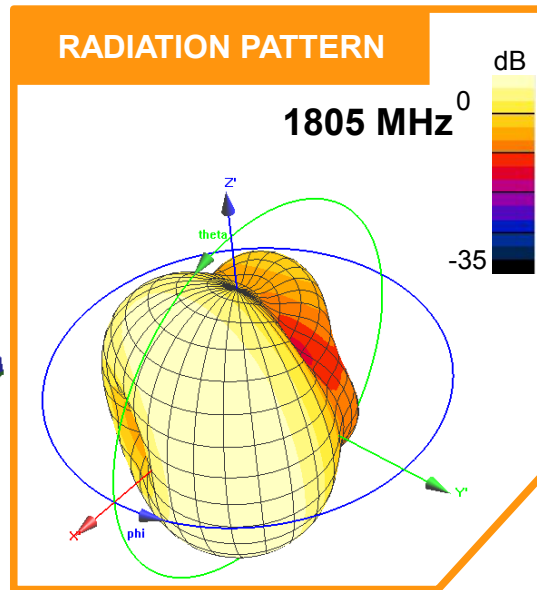
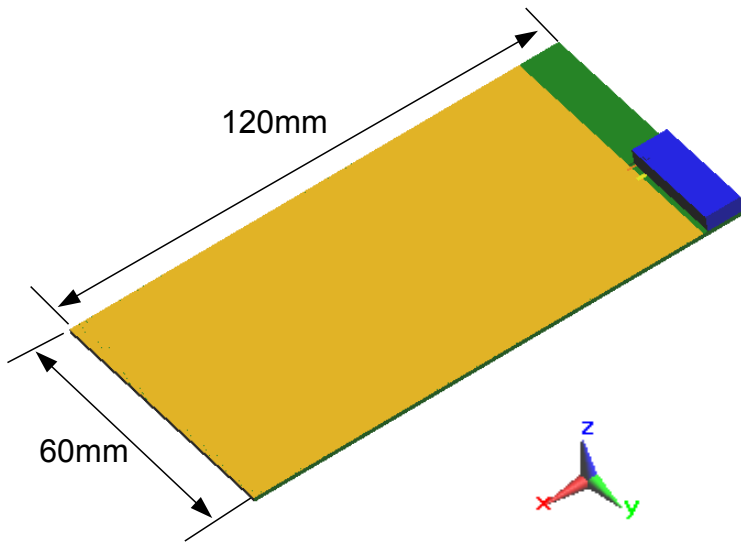
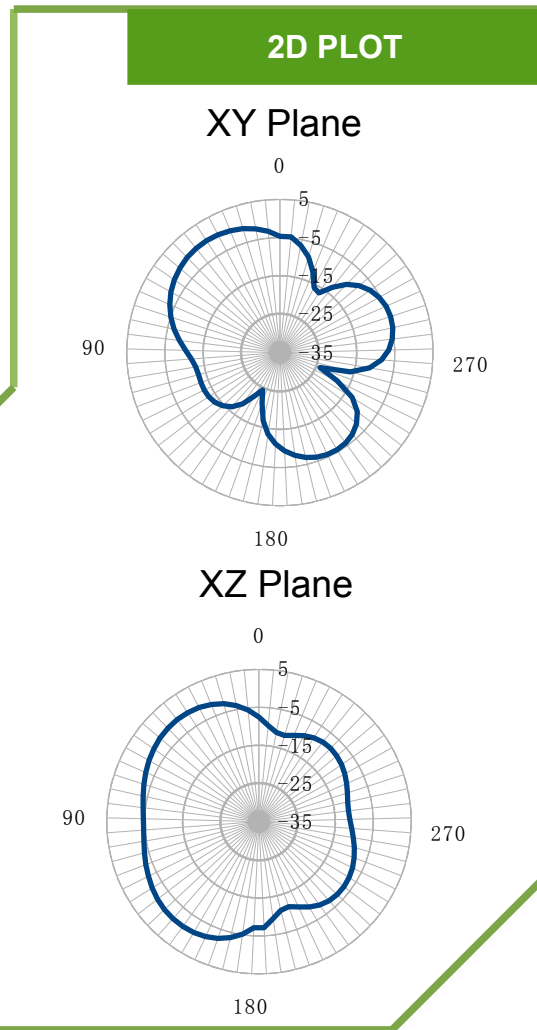

Figure 3, Antenna on reference board

Antenna Placement: Top



# Quadband SMD Antenna

Part No. GA249040QP01

● Performance with reference board

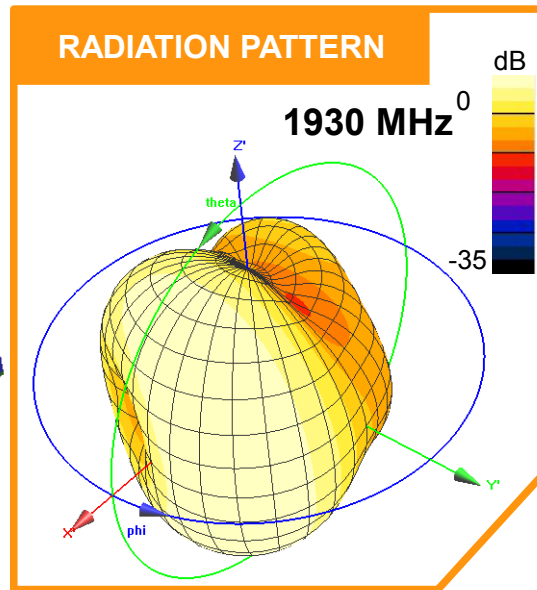
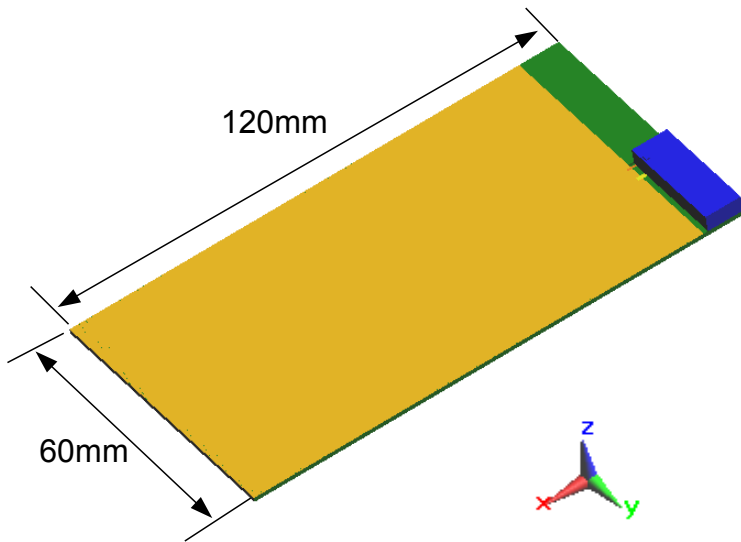
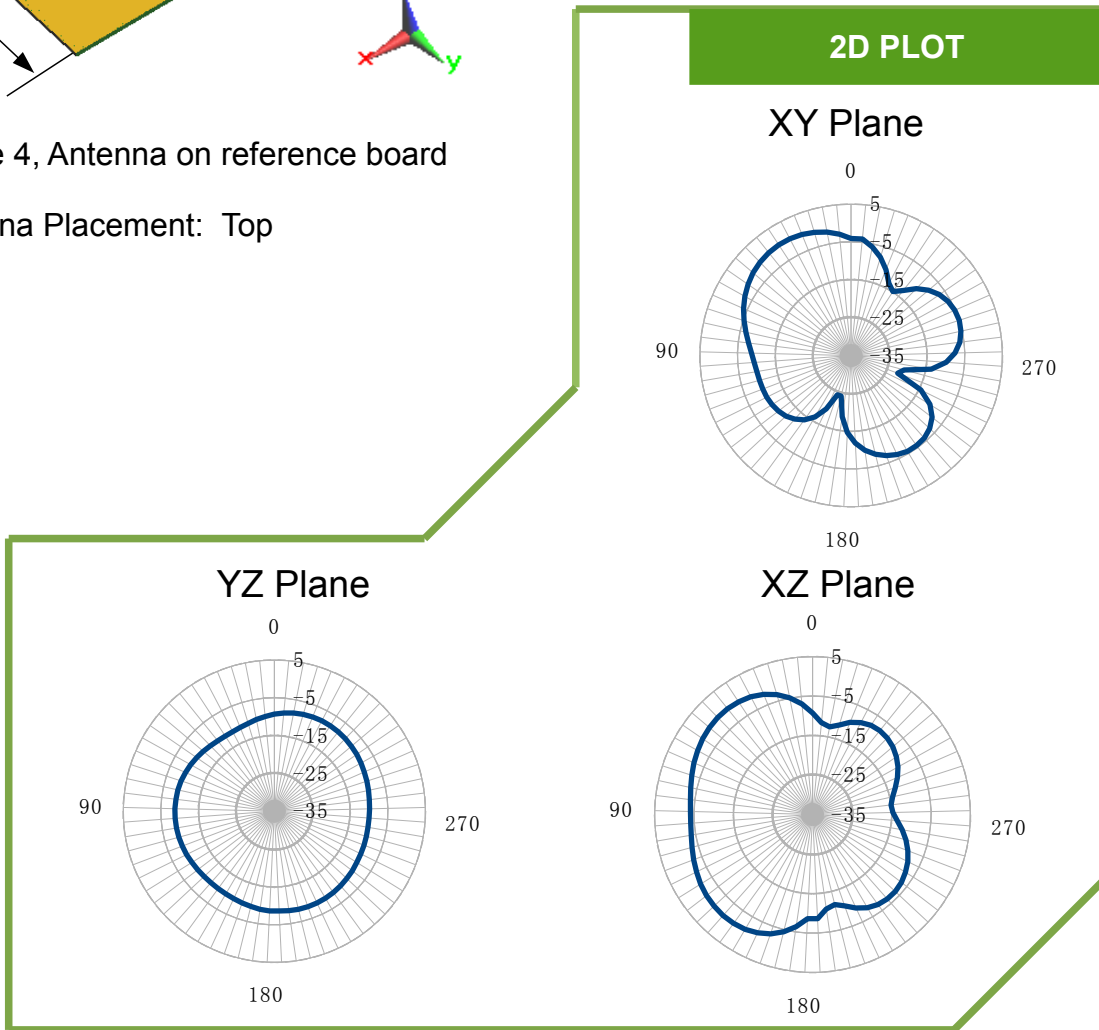

Figure 4, Antenna on reference board

Antenna Placement: Top



GA STANDARD ANTENNA

# Quadband SMD Antenna

Part No. GA249040QP01

## ● Performance with reference board

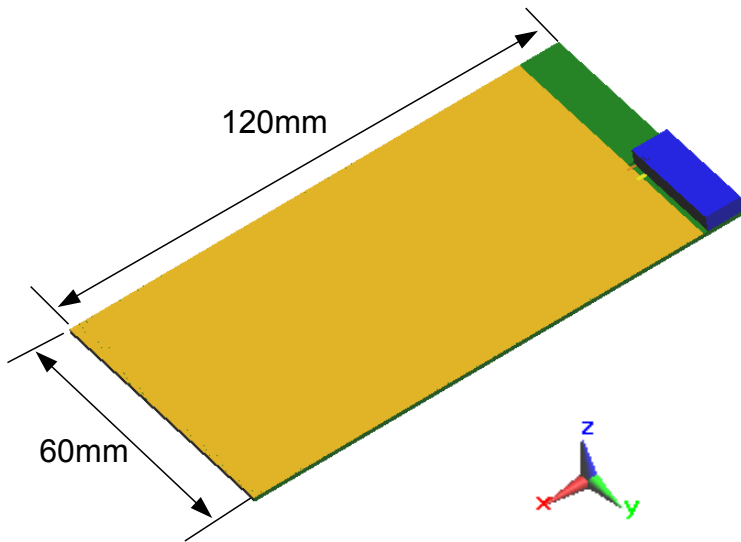
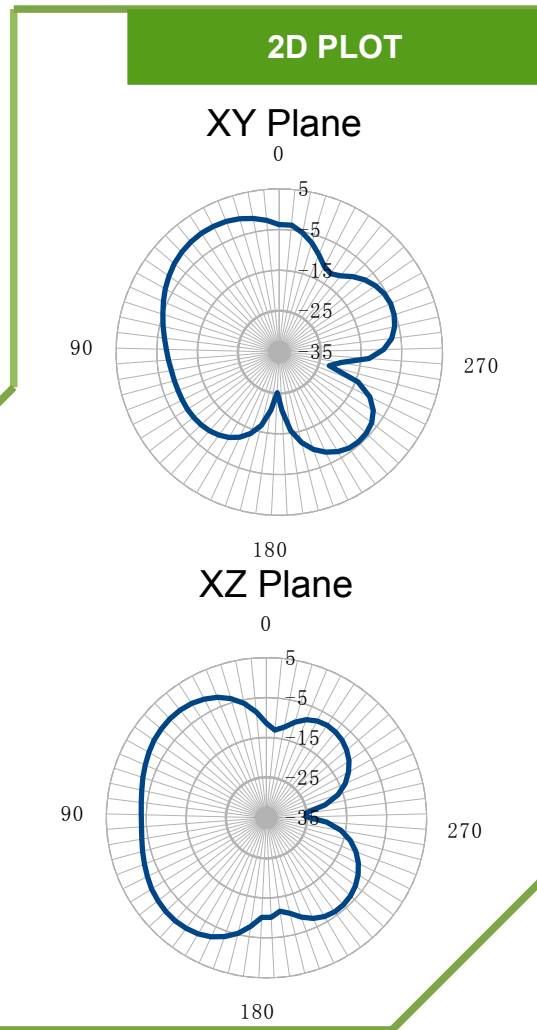
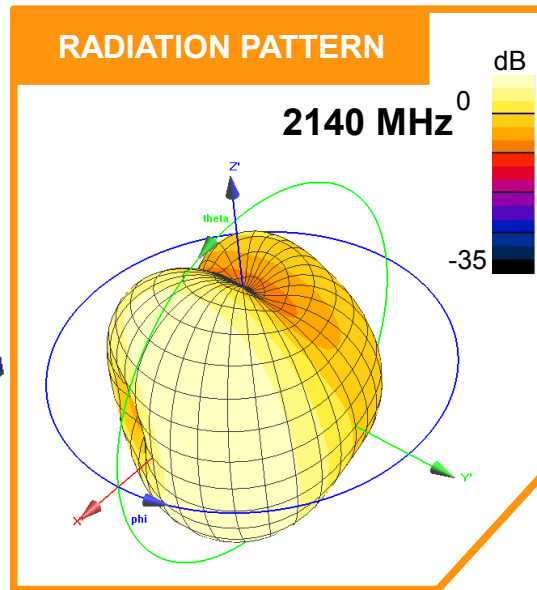

Figure 5, Antenna on reference board

Antenna Placement: Top



# Quadband SMD Antenna

Part No. GA249040QP01

## Antenna Dimension

### Overview

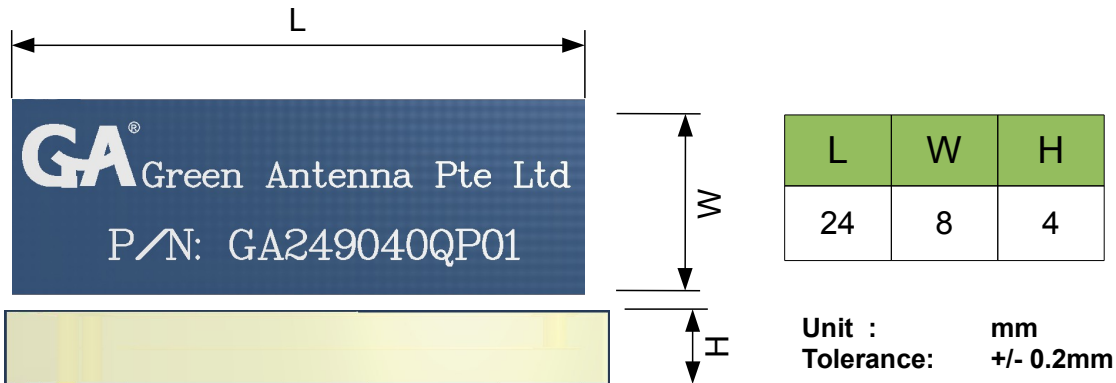

### Layout with side feeding

L	W	G	Pd
24	8	0.3	6.7
Pd2	PI	PI2	Pw
8.7	2	1	2
Pk	K		
3.4	2 to 3		

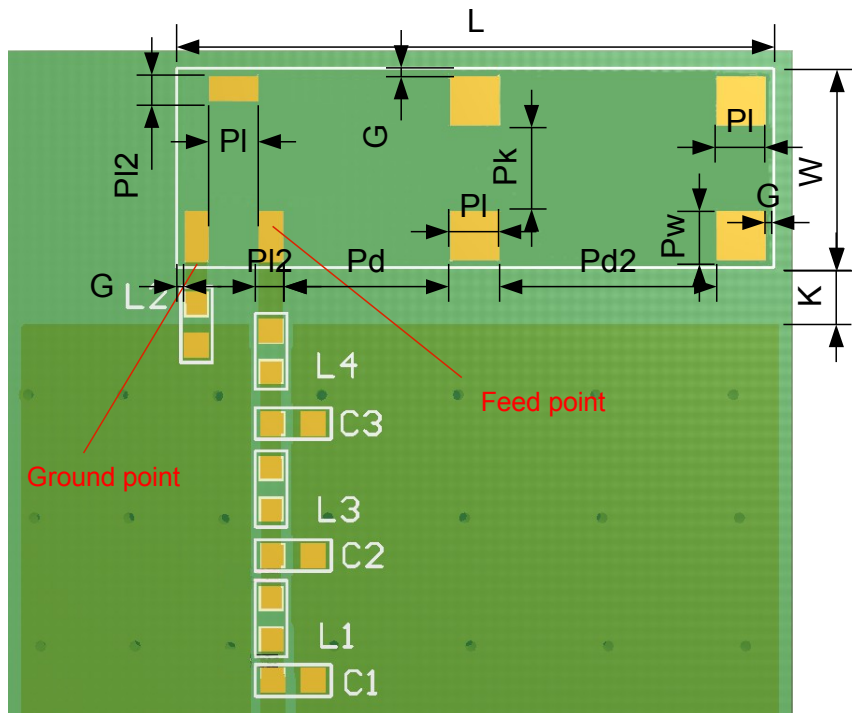

Unit : mm  
Tolerance: +/- 0.1mm

■ : PCB copper  
■ : PCB dielectric  
■ : Pads



# Quadband SMD Antenna

Part No. GA249040QP01



## ➤ Antenna Implementation Guidelines

### ● Transmission Line

- a) Design the transmission line with characteristic impedance of 50 Ohm to feed the antenna.
- b) Minimize the length of transmission line to reduce insertion loss.

### ● Lump Elements Matching Circuit

Placement of antenna, PCB dimension and components within the vicinity of antenna will affect the antenna performance. Therefore, at least **six** lump elements matching circuit **MUST** be reserved for antenna optimization purpose during PCB layout process.

Green Antenna provides optional matching and anechoic chamber measurement services on request. Please contact [ga@green-antenna.com](mailto:ga@green-antenna.com) for further information.

### ● Antenna PCB Placement

To achieve optimum antenna performance, the antenna is recommended to place on the edge of PCB.

Green Antenna provides optional EM simulation service to locate the optimum placement of antenna on customer device or bare PCB board. Please contact [ga@green-antenna.com](mailto:ga@green-antenna.com) for further information.